

BUILDING DESCRIPTION	
VALUATION METHOD:	R - Residential
USE CODE:	R01 - SINGLE FAM DWLG
STYLE:	
FOUNDATION:	C - Continuous Wall
EXTERIOR WALL 1:	AV - Alum/Vinyl
EXTERIOR WALL 2:	
ROOF STRUCTURE:	G - Gable
ROOF COVER:	AS - Asphalt Shingle
BEDROOMS:	2
FULL BATHS:	3
HALF BATHS:	0
GENERATOR:	N
FIREPLACE TYPE/CNT/OPN/CH:	PF/1/1/1
ELEVATOR COUNT:	
PHYS OVERRIDE:	
ECONOMIC DEPRECIATION:	
FUNCTIONAL DEPRECIATION:	
SPECIAL CONDITION CODE:	
SPECIAL CONDITION VALUE:	
DESCRIPTION:	
REMARKS:	
CARD NOTES:	
UNITS:	
HEATED SQUARE FEET:	1,801

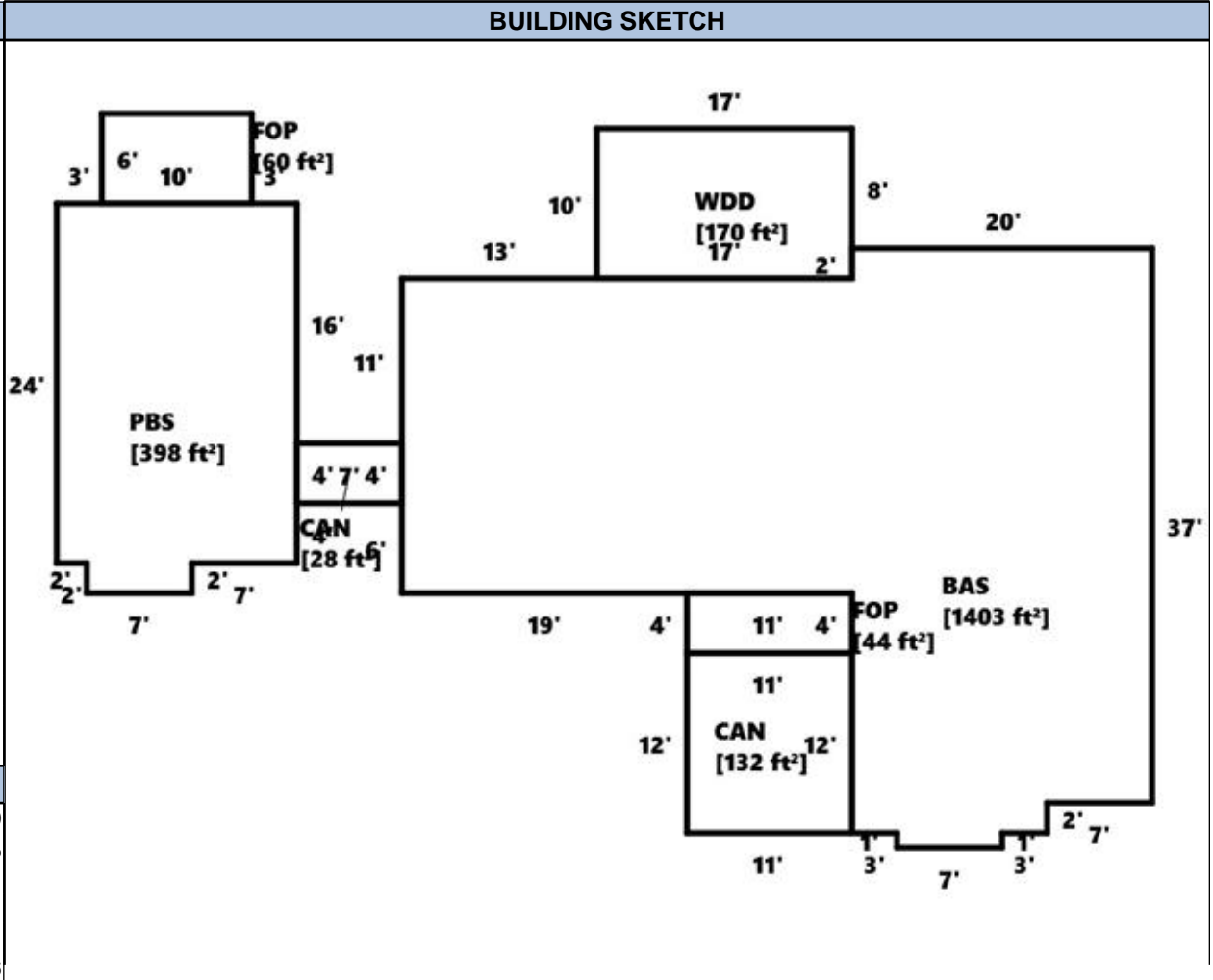

BUILDING COMPUTATION	
REPLACEMENT COST NEW	427,660
PHYSICAL DEPRECIATION	28%
FUNCTIONAL DEPRECIATION	
ECONOMIC DEPRECIATION	
% COMPLETE	
REPLACEMENT COST NEW LESS DEPRECIATION	307,916

BUILDING SECTION DETAIL																
TYPE	AREA	WALL HT	#ST	HEAT TYPE	HEAT%	AIR%	SPK%	GRADE	AYB	EYB	COND	P%	E%	F%	VALUE	
BAS	1403	8.00	1.0	FA		100%		C	1997	1997	A	72%			234,576	
CAN	28		1.0									72%			425	
CAN	132		1.0									72%			2,002	
FOP	44		1.0									72%			2,002	
FOP	60		1.0									72%			2,729	
PBS	398	8.00	1.0	FA		100%			1997	1997	A	72%			62,316	
WDD	170		1.0									72%			3,866	